

FBM204, 0 to 20 mA I/O Interface Module



The FBM204, 0 to 20 mA Input/Output Interface contains four 20 mA dc analog input channels and four 20 mA dc analog output channels.

FEATURES

The key features of the FBM204 are:

- ▶ Four 20 mA dc analog input channels
- ▶ Four 20 mA dc analog output channels
- ▶ Each input and output channel is galvanically isolated
- ▶ Compact, rugged design suitable for enclosure in Class G3 (harsh) environments
- ▶ Execution of an analog I/O application program that provides conversion time and configurable options for Rate of Change Limits
- ▶ High accuracy achieved by sigma-delta data conversions for each channel
- ▶ Termination Assemblies (TAs) for locally or remotely connecting field wiring to the FBM204
- ▶ TA for use with Output Bypass Station to maintain outputs during maintenance operations
- ▶ 3-tier termination assembly for per channel internally and/or externally loop powered transmitters.
- ▶ Support for DPIDA control blocks

INTRODUCTION

The FBM204, 0 to 20 mA Input/Output Interface contains four 0 to 20 mA dc analog input channels and four 0 to 20 mA dc analog output channels. Each input channel accepts an analog sensor input such as a 4 to 20 mA transmitter, or a self-powered 20 mA source. Each output channel drives an external load and produces a 0 to 20 mA output. The inputs/outputs are galvanically isolated from other channels and ground.

The FBM204 performs the signal conversion required to interface the electrical input/output signals from the field sensors to the optionally redundant fieldbus.

The FBM204 executes the Analog I/O application program, which provides the following configurable options: Conversion Time, Fail-Safe Configuration (Hold/Fallback), and Analog Output Fail-Safe Fallback Data (on a per channel basis). When used with I/A Series v8.6 or later software, the FBM may instead execute a distributed PIDA (DPIDA) application program to provide a fast control loop running in it.

When connected to the appropriate TAs, the FBM204 module provides functionality formerly provided by the 100 Series FBM I/O subsystem. TAs are available which support the functionality of the 100 Series FBM04, when the FBM04 is used with non-HART® devices.

HIGH ACCURACY

For high accuracy, the module incorporates Sigma-Delta data conversion on a per channel basis, which provides new analog input readings every 25 ms, and a configurable integration period to remove any process noise and power line frequencies. Each time period, the FBM converts each analog input to a digital value, averages these values over the time period and provides the averaged value to the controller.

COMPACT DESIGN

FBM204 has a compact design, with a rugged extruded aluminum exterior for physical protection of the circuits. Enclosures specially designed for mounting the FBMs provide various levels of environmental protection, up to harsh environments, per ISA Standard S71.04.

VISUAL INDICATORS

Light-emitting diodes (LEDs) incorporated into the front of the module provide visual status indications of Fieldbus Module functions.

EASY REMOVAL/REPLACEMENT

The module can be removed/replaced without removing field device termination cabling, or power or communications cabling.

FIELDBUS COMMUNICATION

A Fieldbus Communications Module or a Control Processor interfaces to the redundant 2 Mbps module Fieldbus used by the FBMs. The FBM accepts communication from either path (A or B) of the 2 Mbps Fieldbus — should one path fail or be switched at the system level, the module continues communication over the active path.

MODULAR BASEPLATE MOUNTING

The module mounts on a DIN rail mounted Modular baseplate, which accommodates up to four or eight Fieldbus Modules. The Modular baseplate is either DIN rail mounted or rack mounted, and includes signal connectors for redundant Fieldbus, redundant independent dc power, and termination cables.

TERMINATION ASSEMBLIES

Field I/O signals connect to the FBM subsystem via DIN rail mounted TAs. The TAs used with the FBM204 are described in "TERMINATION ASSEMBLIES AND CABLES" on page 7.

FUNCTIONAL SPECIFICATIONS

Input/Output Channels

Four 20 mA dc analog input channels, and four 20 mA dc analog output channels. Each channel is isolated and independent.

Input/Output Range (each channel)

0 to 20.4 mA dc

Input Channels (Four) - Specifications

ACCURACY (INCLUDES LINEARITY)

±0.03% of span

Accuracy temperature coefficient: ±50 ppm/°C

INPUT SIGNAL A/D CONVERSION

Each channel performs A/D signal conversion using an independent Sigma-Delta converter.

INPUT CHANNEL IMPEDANCE

61.5 Ω nominal

INTEGRATION PERIOD

Software configurable

COMMON MODE REJECTION

>100 db at 50 or 60 Hz

NORMAL MODE REJECTION

>95 db at 50 or 60 Hz

FIELD DEVICE CABLING DISTANCE

Maximum distance of the field device from the FBM is a function of compliance voltage (20.2 V dc at 20.4 mA input), wire gauge, and voltage drop at the field device.

LOOP POWER SUPPLY PROTECTION

Each channel is channel-to-channel galvanically isolated, current limited, and voltage regulated. All analog inputs are limited by their design to less than 30 mA. If the current limit circuit shorts out, the current is limited to about 100mA.

Output Channels (Four) - Specifications

ACCURACY - ANALOG (INCLUDES LINEARITY)

±0.03% of Span

Accuracy temperature coefficient: ±50 ppm/°C

OUTPUT LOAD

750 Ω maximum

OUTPUT PROCESSING DELAY

30 ms maximum

RESOLUTION

13 bits

FIELD DEVICE CABLING DISTANCE

Maximum distance of the field device from the FBM is a function of compliance voltage (19.6 V dc at 20.4 mA input), wire gauge, and voltage drop at the field device.

LOOP POWER SUPPLY PROTECTION

Each channel is channel-to-channel galvanically isolated, current limited, and voltage regulated. All analog outputs are limited by their design to about 25 mA. If the output FET shorts, the output current could increase up to 35 mA. In normal operation the FBM outputs a constant current into a 0 to 750 ohm load.

HART® PROTOCOL COMPATIBILITY

The channels meet the impedance requirements for a HART high Impedance Device and can be used in a HART loop without interfering with the HART signals between the field device and a Hand-Held Communicator (HHC).

If a FoxCom or HART transmitter is used as an "input device" to the FBM204, a 200 ohm in-line resistor (assembly part number P0902VY) must be added in series with the transmitter.

Input/Output Channel Isolation

Each channel is galvanically isolated from all other channels and earth (ground). The module withstands, without damage, a potential of 600 V ac applied for one minute between any channel and ground, or between a given channel and any other channel. See CAUTION below.

CAUTION

This does not imply that these channels are intended for permanent connection to voltages of these levels. Exceeding the limits for input voltages, as stated elsewhere in this specification, violates electrical safety codes and may expose users to electric shock.

FUNCTIONAL SPECIFICATIONS (CONTINUED)

Communication

Communicates with its associated FCM or FCP via the redundant 2 Mbps module Fieldbus.

Power Requirements

INPUT VOLTAGE RANGE (REDUNDANT)

24 V dc +5%, -10%

CONSUMPTION (MAXIMUM)

7 W (maximum)

HEAT DISSIPATION (MAXIMUM)

3.5 W (maximum)

Calibration Requirements

Calibration of the module and termination assembly is not required.

Regulatory Compliance

ELECTROMAGNETIC COMPATIBILITY (EMC)

European EMC Directive 89/336/EEC

Meets: EN 50081-2 Emission standard
EN 50082-2 Immunity standard
EN 61326 Annex A (Industrial

Levels)

CISPR 11, Industrial Scientific and Medical (ISM) Radio-frequency Equipment -

Electromagnetic Disturbance Characteristics - Limits and Methods of Measurement

Meets: Class A Limits

IEC 61000-4-2 ESD Immunity

Contact 4 kV, air 8 kV

IEC 61000-4-3 Radiated Field Immunity

10 V/m at 80 to 1000 MHz

IEC 61000-4-4 Electrical Fast

Transient/Burst Immunity

2 kV on I/O, V dc power and communication lines

IEC 61000-4-5 Surge Immunity

2kV on ac and dc power lines; 1kV on I/O and communications lines

IEC 61000-4-6 Immunity to Conducted Disturbances induced by Radio-frequency Fields

10 V (rms) at 150 kHz to 80 MHz on I/O, V dc power and communication lines

IEC 61000-4-8 Power Frequency Magnetic

Field Immunity

30 A/m at 50 and 60 Hz

PRODUCT SAFETY

Underwriters Laboratories (UL) for U.S. and Canada

UL/UL-C listed as suitable for use in UL/UL-C listed Class I, Groups A-D; Division 2; temperature code T4 enclosure based systems. These modules are also UL and UL-C listed as associated apparatus for supplying non-incendive communication circuits for Class I, Groups A-D hazardous locations when connected to specified I/A Series[®] processor modules as described in the *I/A Series DIN Rail Mounted Subsystem User's Guide* (B0400FA).

Communications circuits also meet the requirements for Class 2 as defined in Article 725 of the National Electrical Code (NFPA No.70) and Section 16 of the Canadian Electrical Code (CSA C22.1). Conditions for use are as specified in the *I/A Series DIN Rail Mounted Subsystem User's Guide* (B0400FA).

European Low Voltage Directive 73/23/EEC and Explosive Atmospheres (ATEX) directive 94/9/EC

CENELEC (DEMKO) certified as EEx nA IIC T4 for use in CENELEC certified Zone 2 enclosure certified as associated apparatus for supplying non-incendive field circuits for Zone 2, Group IIC, potentially explosive atmospheres when connected to specified I/A Series processor modules as described in the *I/A Series DIN Rail Mounted Subsystem User's Guide* (B0400FA). Also see, Table 1 on page 8.

NOTE

CENELEC (DEMKO) Certification does not apply to Termination Assembly P0917QW. See Table 1 on page 8.

ENVIRONMENTAL SPECIFICATIONS⁽¹⁾

Operating Conditions

TEMPERATURE

Module

-20 to +70°C (-4 to +158°F)

Termination Assembly

PVC

-20 to +50°C (-4 to +122°F)

PA

-20 to +70°C (-4 to +158°F)

RELATIVE HUMIDITY

5 to 95% (noncondensing)

ALTITUDE

-300 to +3000 m (-1000 to +10 000 ft)

Storage Conditions

TEMPERATURE

-40 to +70°C (-40 to +158°F)

RELATIVE HUMIDITY

5 to 95% (noncondensing)

ALTITUDE

-300 to +12 000 m (-1000 to +40 000 ft)

Contamination

Suitable for use in Class G3 (Harsh) environments as defined in ISA Standard S71.04, based on exposure testing according to EIA Standard 364-65, Class III.

Vibration

7.5 m/s² (5 to 500 Hz)

PHYSICAL SPECIFICATIONS

Mounting

MODULE

FBM204 mounts on a baseplate. The baseplate can be mounted on a DIN rail (horizontally or vertically), or horizontally on a 19-inch rack using a mounting kit. Alternatively, FBM204 mounts on a 100 Series conversion mounting structure. Refer to *DIN Rail Mounted Modular Baseplates* (PSS 21H-2W6 B4) or *100 Series Conversion Mounting Structures* (PSS 21H-2W8 B4) for details.

TERMINATION ASSEMBLY

The TA mounts on a DIN rail and accommodates multiple DIN rail styles including 32 mm (1.26 in) and 35 mm (1.38 in)

Mass

MODULE

284 g (10 oz) approximate

TERMINATION ASSEMBLIES

Compression

159 g (0.35 lb, approximate)

Ring Lug

204 g (0.45 lb, approximate)

Dimensions - Module

HEIGHT

102 mm (4 in), 114 mm (4.5 in) including mounting lugs

WIDTH

45 mm (1.75 in)

DEPTH

104 mm (4.11 in)

Dimensions - Termination Assemblies

Refer to page 9

Part Numbers

FBM204 MODULE

P0914SY

TERMINATION ASSEMBLIES

See "FUNCTIONAL SPECIFICATIONS - TERMINATION ASSEMBLIES" on page 7.

(1) The environment ranges can be extended by the type of enclosure containing the module. Refer to the Product Specification Sheet (PSS) applicable to the enclosure that is to be used.

PHYSICAL SPECIFICATIONS (CONTINUED)

Termination Cables

CABLE LENGTHS

Up to 30 m (98 ft)

CABLE MATERIALS

Polyurethane or Low Smoke Zero Halogen (LSZH)

TERMINATION CABLE TYPE

Type 1 - Refer to Table 2

FBM Baseplate End

37-pin D-subminiature

Termination Assembly End

25-pin D-subminiature

Construction - Termination Assembly

MATERIAL

Polypropylene (PVC), compression

Polyamide (PA), compression

PVC, ring lug

Field Termination Connections

COMPRESSION - ACCEPTED WIRING SIZES

Solid/Stranded/AWG

0.2 to 4 mm²/0.2 to 2.5 mm²/24 to 12 AWG

Stranded with Ferrules

0.2 to 2.5 mm² with or without plastic collar

RING-LUG - ACCEPTED WIRING SIZES

#6 size connectors (0.375 in (9.5 mm))

0.5 to 4 mm²/22 AWG to 12 AWG

TERMINATION ASSEMBLIES AND CABLES

Field I/O signals connect to the FBM subsystem via DIN rail mounted termination assemblies, which are electrically passive. TAs for the FBM204 module are available in the following forms:

- ▶ Compression screw type using Polyvinyl Chloride (PVC) and Polyamide (PA) material
- ▶ Ring lug type using Polyvinyl Chloride (PVC) material.

Each FBM204 Termination Assembly and its associated termination cable provide feedthrough connection between four 2-wire analog input signals and four 2-wire analog output signals, and the FBM204, 0 to 20 mA I/O Interface Module.

Termination Assembly (P0917QW) includes built-in bypass jacks for each output channel. Jacks accept a bypass plug from the I/A Series Output Bypass

Station (Invensys P/N P0900HJ) or other external 20 mA sources. This option should be considered for applications where maintaining output during maintenance operations is desired.

A removable termination cable connects the DIN rail mounted TA to the FBM via a field connector on the baseplate in which the FBM is installed. Termination cables are available in the following materials:

- ▶ Polyurethane
- ▶ Low Smoke Zero Halogen (LSZH).

Termination cables are available in a variety of lengths, up to 30 meters (98 feet), allowing the termination assembly to be mounted in either the enclosure or in an adjacent enclosure. See Table 2 for a list of termination cables used with the TAs for the FBM204 module.

FUNCTIONAL SPECIFICATIONS - TERMINATION ASSEMBLIES

FBM Type	Input		Output		TA Part No.(a)	TA Part No.(a)	Termination Type(b)	TA Cable Type (c)	TA Cert. Type (d)
	Qty	Signal	Qty.	Signal	PVC	PA			
FBM204	4	0 to 20 mA	4	0 to 20 mA	P0916AG/ P0916AH	P0916XK	C RL	1	1
FBM204	4	0 to 20 mA	4	0 to 20 mA	P0917QW		C	1	4,5

(a) PVC is polyvinyl chloride rated from -20 to +50°C (-4 to +122°F); PA is polyamide rated from -20 to +70°C (-4 to +158°F).

(b) C = TA with compression terminals; RL = TA with ring lug terminals.

(c) See Table 2 for cable part numbers and specifications.

(d) See Table 1 for Termination Assembly certification definitions.

Table 1. Certification for Termination Assemblies

Type	Certification
Type 1	TAs are UL/UL-C listed as suitable for use in Class I; Groups A-D; Division 2 temperature code T4 hazardous locations. They are GENELEC (DEMKO) certified EEx nA IIC T4 for use in Zone 2 potentially explosive atmospheres.
Type 4	All field circuits are Class 2 limited energy (60 V dc, 30 V ac, 100 VA or less) if customer-supplied equipment meets Class 2 limits.
Type 5	The TA and its field circuitry are for use in only ordinary (non-hazardous) locations.

Table 2. Cables Types and Part Numbers

Cable Length m (ft)	Type 1 P/PVC (a)	Type 1 LSZH (b)	Type 1 H/XLPE(c)
0.5 (1.6)	P0916DA	P0928AA	P0916VA
1.0 (3.2)	P0916DB	P0928AB	P0916VB
2.0 (6.6)	P0931RM	P0928AC	P0931RR
3.0 (9.8)	P0916DC	P0928AD	P0916VC
5.0 (16.4)	P0916DD	P0928AE	P0916VD
10.0 (32.8)	P0916DE	P0928AF	P0916VE
15.0 (49.2)	P0916DF	P0928AG	P0916VF
20.0 (65.6)	P0916DG	P0928AH	P0916VG
25.0 (82.0)	P0916DH	P0928AJ	P0916VH
30.0 (98.4)	P0916DJ	P0928AK	P0916VJ

- (a) P/PVC is polyurethane outer jacket and semi-rigid PVC primary conductor insulation. Temperature range; -20 to +80°C (-4 to +176°F).
- (b) Low smoke zero halogen or low smoke free of halogen (LSZH) is a material classification used for cable jacketing. LSZH is composed of thermoplastic or thermoset compounds that emit limited smoke and no halogen when exposed to high sources of heat. Temperature range; -40 to +105°C (-40 to +221°F)
- (c) H/XLPE is Hypalon outer jacket and XLPE (cross-linked polyethylene) primary conductor insulation. Temperature range; -40 to +90°C (-40 to +194°F). Hypalon cables are no longer available for purchase

Use of Termination Assemblies in 100 Series Upgrade Subsystem

When an FBM204 is used to replace the 100 Series FBM04, it may use any of the appropriate termination assemblies listed above for the FBM04's field I/O

wiring. Alternatively, the FBM204 can accept this field wiring through a Termination Assembly Adapter (TAA) instead of a termination assembly. This is discussed in *Termination Assembly Adapter Modules for 100 Series Upgrade* (PSS 21H-2W4 B4).

DIMENSIONS—NOMINAL

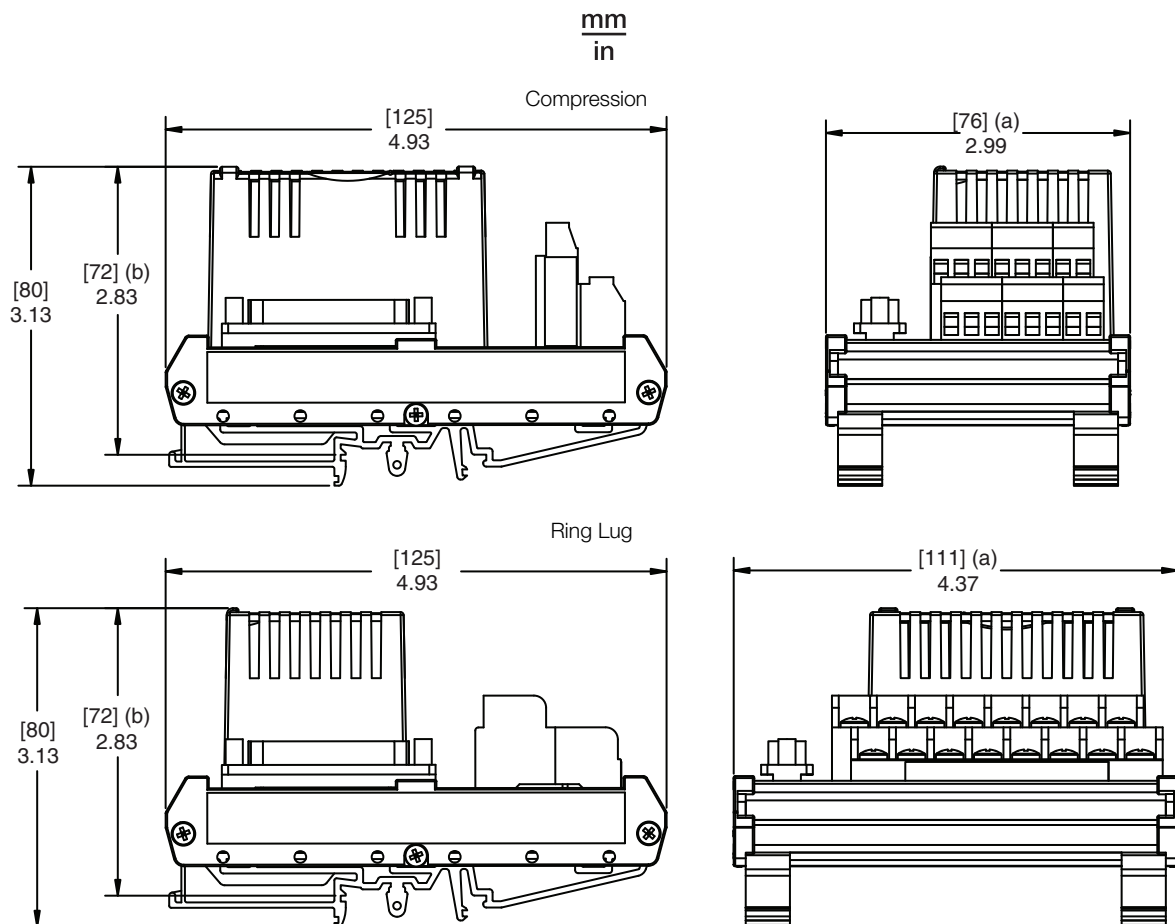

(a) Overall width – for determining DIN rail loading.

(b) Height above DIN rail (add to DIN rail height for total).

RELATED PRODUCT SPECIFICATION SHEETS (PSS)

PSS Number	Description
PSS 21H-2W1 B3	DIN Rail Mounted FBM Subsystem Overview
PSS 21H-2W1 B4	100 Series Fieldbus Module Upgrade Subsystem Overview
PSS 21H-2W2 B3	DIN Rail Mounted FBM Equipment, Agency Certification
PSS 21H-2W4 B4	Termination Assembly Adapter Modules for 100 Series Upgrade
PSS 21H-2W6 B4	DIN Rail Mounted Modular Baseplates
PSS 21H-2W8 B4	100 Series Conversion Mounting Structures
PSS 21S-3B2 B3	Control Processor 270 (CP270) Integrated Control Software

